

FACTORY AUTOMATION

The next level of industry

MELSEC iQ-F series

Introduction proposal



The MELSEC iQ-F series is an evolution of the MELSEC-F series, offering high basic performance and a wealth of built-in features.

With the addition of the FX5S, the replacement range has been expanded.

Point 1 Improved usability

- Reduce I/O wiring costs and man-hours

MELSEC-F

There are two types of wiring methods.

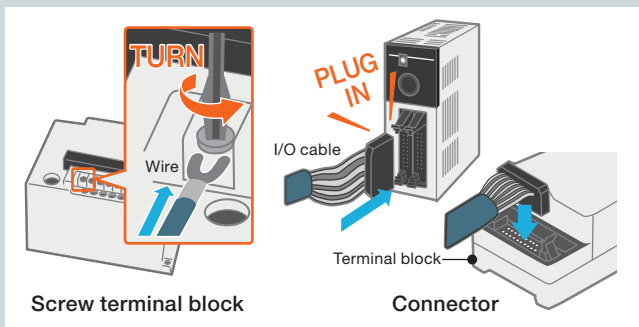

MELSEC iQ-F series

There are three types of wiring methods. The additional spring clamp terminal block can be wired in a single operation, reducing the wiring.

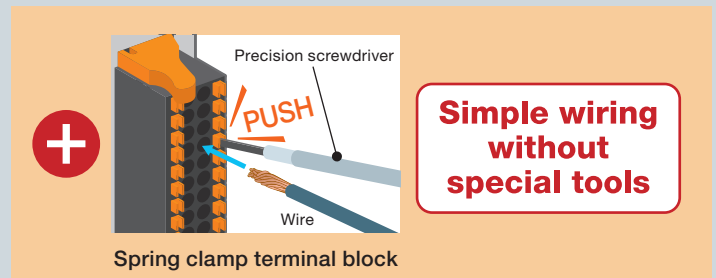

- Reduce programming man-hours

MELSEC-F

A special program is required to set the module parameters.

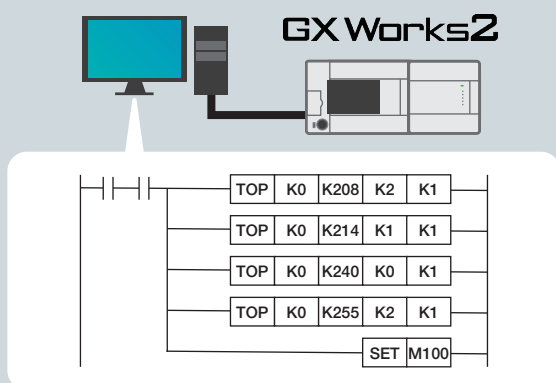

MELSEC iQ-F series

Without a program, module parameters can be set directly with an engineering tool.

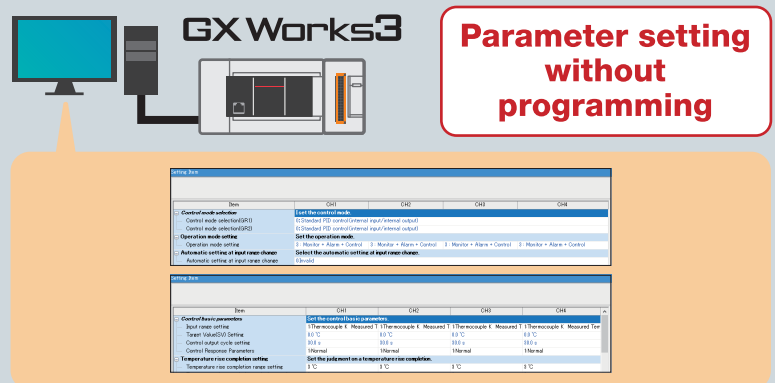

Parameter setting without programming

Point 2

Improved built-in functions

• Data communication with external devices via built-in function

MELSEC-F

Data communication with external devices requires expansion devices and programs.

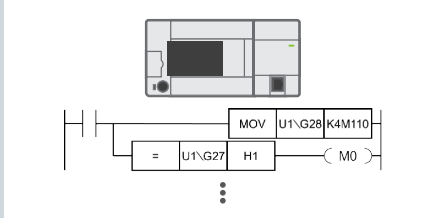

MELSEC iQ-F series

Send and receive device data to and from an Ethernet-equipped module with simple parameter settings.

Simple CPU communication function

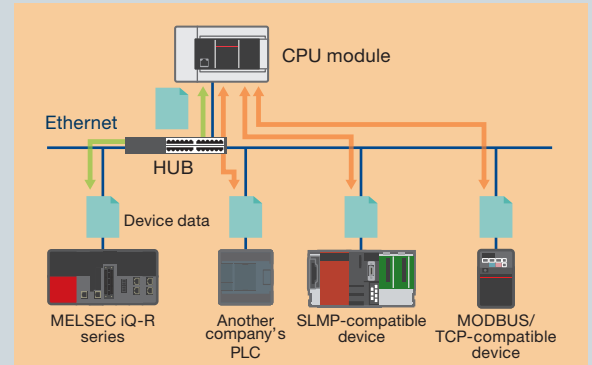

• Improved logging function

MELSEC-F

Special programs and additional equipment are required.

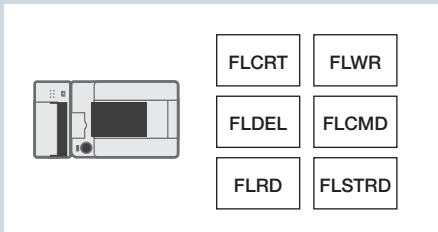

MELSEC iQ-F series

The built-in logging function does not require a program, and detailed logging conditions can be set using a dedicated setting tool. Logging data can also be collected from remote locations.

Ease of use and improved maintenance efficiency

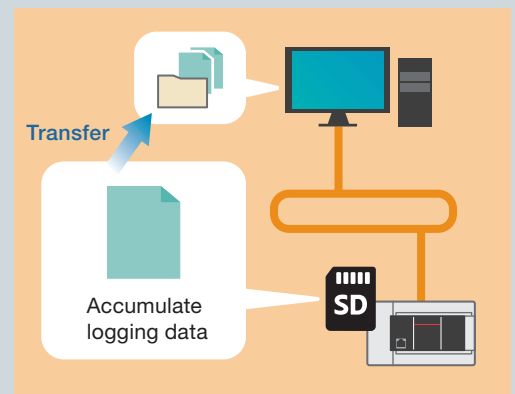

Point 3

Advanced drive control

• Create a high degree of freedom servo system

MELSEC-F

Simple servo system control is supported.

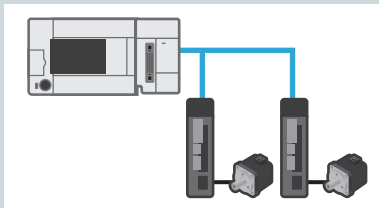

MELSEC iQ-F series

Multi-axis motion control is supported, and devices other than servo amplifiers can be connected via CC-Link IE TSN.

Enhanced functionality, performance and accuracy

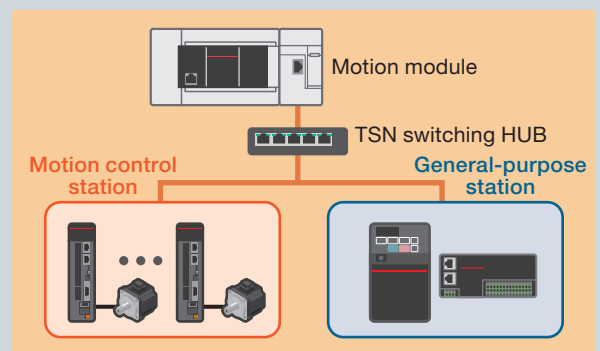

We also have a handbook for transitioning from the MELSEC-F series to the MELSEC iQ-F series.

Transition from MELSEC FX3G, FX3U, FX3UC Series to MELSEC iQ-F Series Handbook
<JY997D66201>



MITSUBISHI ELECTRIC CORPORATION

Please contact your nearest Mitsubishi Electric representative for more information.

⚠ Safety Warning

To ensure proper use of the products in this document, please be sure to read the instruction manual prior to use.

Registration

The company names, system names and product names mentioned in this manual are either registered trademarks or trademarks of their respective companies.
In some cases, trademark symbols such as "™" or "®" are not specified in this document.