

第7編 クーリングタワーII

機種一覧表<クーリングタワーII>

形名		能力	冷 却 <RT>																		
			80	100	125	150	175	200	225	250	300	350	400	450	500	600	700	800	900	1000	
三菱樹脂株式会社	丸形	標準形 HT-Cb	○	○	○	○	○	○	○												
		低騒音I形 HT-SQb	○	○	○	○	○	○	○												
	角形	標準形 HT-MS・Lc		○	○	○	○	○	○	○	○	○	○	○	○	○	○	○	○	○	○
		低騒音形 HT-ME・Lc		○	○	○	○	○	○	○	○	○	○	○	○	○	○	○	○	○	○
		超低騒音I形 HT-MQ・Lc		○	○	○	○	○	○	○	○	○	○	○	○	○	○	○	○	○	○
		超低騒音II形 HT-MQQ・Lc		○	○	○	○	○	○	○	○	○	○	○	○	○	○	○	○	○	○
密閉式 PS・PE形	○	○	○	○	○	○	○	○	○	○	○	○	○								
空研工業株式会社	角形	低騒音形 SKB-PoR	○	○	○	○	○	○	○	○	○	○	○	○	○	○	○	○	○	○	
		低騒音形 SKB-PoGR	※ ○	○	○	※ ○	※ ○	※ ○	○	※ ○	※ ○										
		超低騒音形 SKB-PoRS	○	○	○	○	○	○	○	○	○	○	○	○	○	○	○	○	○	○	○
		超低騒音形 SKB-PoGRS	※ ○	○	○	※ ○	※ ○	※ ○	○	※ ○	※ ○										
	形	密閉式低騒音形 KCMB-R	○	○	○	○	○	○	○	○	○	○	○	○	○	○	△	△	△	△	
		密閉式超低騒音形 KCMB-RS	○	○	○	○	○	○	○	○	○	○	○	○	○	○	△	△	△	△	

※印は+5RTの容量のものです。△印は引当可能ですのでご相談ください。

目次

7.1 三菱樹脂株式会社	1195
(1) 丸形仕様	1195
(a) 標準形<Cb形>	1195
(b) 低騒音形<SQb形>	1195
(2) 角形仕様	1196
(a) 標準形<MS・Lc形>	1196
(b) 低騒音形<ME・Lc形>	1196
(c) 超低騒音I形<MQ・Lc形>	1197
(d) 超低騒音II形<MQQ・Lc形>	1197
(3) 丸形構造図	1198
(4) 角形構造図	1198
(5) 密閉式タワー	1199
(a) 標準形<PS形>	1199
(b) 低騒音形<PE形>	1199
7.2 空研工業株式会社	1200
(1) 低騒音形<SKB-PoR形>	1200
(2) 低騒音形<SKB-PoGR形>	1201
(3) 超低騒音形<SKB-PoRS形>	1202
(4) 超低騒音形<SKB-PoGRS形>	1203
(5) 密閉式低騒音形<KCMB-R形>	1204
(6) 密閉式超低騒音形<KCMB-RS形>	1205

(1)丸形仕様

(a)標準形<Cb形>

機種	水量	外形寸法		重量		送風機			配管サイズ<A>				
		H	D	製品	運転時	径	電動機	台数	循環水 入口・出口	手動自動 給水口	オーバ フロー	排水口	
HT-Cb	<m ³ /h>	<mm>	<mm>	<kg>	<kg>	<mm>	<kW>	<台>					
50Hz地区	125	97.5	2,930	2,710	555	1,690	800	2.2	2	125	25	40	40
	150	117.0	2,960	2,960	750	1,950	800	1.1	3	150	25	50	50
	175	136.5	3,040	3,260	830	2,100	800	1.1・2.2	1・2	150	25	50	50
	200	156.0	3,090	3,470	900	2,170	800	2.2	3	150	32	50	50
	250	195.0	3,240	3,860	1,180	2,780	800	2.2	4	200	40	80	50
60Hz地区	125	97.5	2,930	2,710	555	1,680	800	1.1	2	125	25	40	40
	150	117.0	2,960	2,960	720	1,920	800	2.2	2	150	25	50	50
	175	136.5	3,040	3,260	820	2,090	800	1.1	3	150	25	50	50
	200	156.0	3,090	3,470	880	2,160	800	1.1・2.2	2・1	150	32	50	50
	250	195.0	3,240	3,860	1,110	2,710	800	1.1	4	200	40	80	50

(b)低騒音形<SQb形>

機種	水量	外形寸法		重量		送風機			配管サイズ<A>				
		H	D	製品	運転時	径	電動機	台数	循環水 入口・出口	手動自動 給水口	オーバ フロー	排水口	
HT-SQb	<m ³ /h>	<mm>	<mm>	<kg>	<kg>	<mm>	<kW>	<台>					
50Hz地区	125	97.5	3,180	2,710	565	1,700	800	2.2	2	125	25	40	40
	150	117.0	3,210	2,960	760	1,960	800	1.1	3	150	25	50	50
	175	136.5	3,290	3,260	840	2,110	800	1.1・2.2	1・2	150	25	50	50
	200	156.0	3,340	3,470	910	2,180	800	2.2	3	150	32	50	50
	250	195.0	3,490	3,860	1,190	2,790	800	2.2	4	200	40	80	50
60Hz地区	125	97.5	3,180	2,710	565	1,700	800	1.1	2	125	25	40	40
	150	117.0	3,210	2,960	730	1,930	800	2.2	2	150	25	50	50
	175	136.5	3,290	3,260	830	2,100	800	1.1	3	150	25	50	50
	200	156.0	3,340	3,470	890	2,170	800	1.1・2.2	2・1	150	32	50	50
	250	195.0	3,490	3,860	1,120	2,710	800	1.1	4	200	40	80	50

標準形運転音<Cb形>

単位：dB<A>

機種	ルーバ横 高さ1.5m				
	5m	10m	15m	20m	
HT-Cb					
50Hz地区	125	67.5	63.5	60.5	58.5
	150	68.5	65	63	61
	175	69	65	62	60
	200	71	67.5	65.5	63.5
	250	70	66	63	61
60Hz地区	125	67.5	63.5	60.5	58.5
	150	69	66	64	62
	175	71	68	65	63
	200	72	68	66	64
	250	73	69	66	64

低騒音形運転音<SQb形>

単位：dB<A>

機種	ルーバ横 高さ1.5m				
	5m	10m	15m	20m	
HT-SQb					
50Hz地区	125	59	54.5	52	50
	150	60	56	53	51
	175	61.5	57	54.5	52
	200	62	58	55	53
	250	63	59	56	54
60Hz地区	125	62	58	55	53
	150	63	59	56	54
	175	63.5	59	56.5	54.5
	200	65	60.5	58	56
	250	66	62	59	57

(2)角形仕様

(a)標準形<MS・Lc形>

機種	水量 <m ³ /h>	外形寸法				重量		送風機		配管サイズ<A>			
		L <mm>	W <mm>	H <mm>	h <mm>	製品 <kg>	運転 <kg>	径 <D>	定格出力 <kW>×台	入口	出口	自動 手動	オーバ 排水
100	78.0	3,260	1,460	2,700	690	920	1,870	1,200	3.7×1	80×2	125×1	25×1	65×1
125	97.5	3,460	1,660	2,700	710	980	2,040	1,400	3.7×1	100×2	125×1	25×1	65×1
150	117.0	3,460	1,860	2,700	710	1,020	2,180	1,400	5.5×1	100×2	150×1	25×1	65×1
175	136.5	3,660	1,860	2,700	740	1,030	2,220	1,600	5.5×1	100×2	150×1	25×1	65×1
200	156.0	3,660	2,260	2,700	830	1,150	2,530	1,600	5.5×1	125×2	150×1	32×1	65×1
225	175.5	3,860	2,460	2,700	830	1,360	2,870	1,800	5.5×1	125×2	200×1	32×1	65×1
250	195.0	4,060	2,860	2,700	850	1,470	3,210	2,000	5.5×1	125×2	200×1	32×1	65×1
300	234.0	3,460	3,260	2,700	710	1,660	3,470	1,400	5.5×2	150×2	200×1	32×1	65×1
350	273.0	3,660	3,660	2,700	740	1,780	3,830	1,600	5.5×2	150×2	200×1	32×1	65×1
400	312.0	3,860	4,060	2,700	830	2,150	4,770	1,800	5.5×2	125×4	150×2	32×2	65×2
450	351.0	4,060	4,460	2,700	850	2,280	5,150	2,000	5.5×2	125×4	200×2	32×2	65×2
500	390.0	4,060	4,860	2,700	850	2,630	5,710	2,000	7.5×2	125×4	200×2	32×2	65×2
600	468.0	3,660	6,460	2,700	740	3,040	6,760	1,600	5.5×3	150×4	200×2	32×2	65×2
700	546.0	3,860	7,260	2,700	830	3,450	7,650	1,800	5.5×3	150×4	200×2	32×2	65×2
800	624.0	3,860	8,060	2,700	830	4,090	8,970	1,800	5.5×4	125×8	200×3	32×3	65×3
900	702.0	3,860	8,860	2,700	830	4,330	9,630	1,800	5.5×4	125×8	200×3	32×3	65×3
1000	780.0	4,060	9,660	2,700	850	4,980	10,790	2,000	7.5×4	125×8	200×3	32×3	65×3

(b)低騒音形<ME・Lc形>

機種	水量 <m ³ /h>	外形寸法				重量		送風機		配管サイズ<A>			
		L <mm>	W <mm>	H <mm>	h <mm>	製品 <kg>	運転 <kg>	径 <D>	定格出力 <kW>×台	入口	出口	自動 手動	オーバ 排水
100	78.0	3,460	1,660	2,700	710	980	2,040	1,400	2.2×1	80×2	125×1	25×1	65×1
125	97.5	3,660	1,860	2,700	740	1,050	2,230	1,600	2.2×1	100×2	125×1	25×1	65×1
150	117.0	3,660	2,060	2,700	740	1,180	2,390	1,600	3.7×1	100×2	150×1	25×1	65×1
175	136.5	3,860	2,260	2,700	830	1,200	2,610	1,800	3.7×1	100×2	150×1	25×1	65×1
200	156.0	3,860	2,460	2,700	830	1,350	2,860	1,800	5.5×1	125×2	150×1	32×1	65×1
225	175.5	3,860	2,860	2,700	830	1,470	3,170	1,800	5.5×1	125×2	200×1	32×1	65×1
250	195.0	4,060	3,260	2,700	850	1,630	3,580	2,000	5.5×1	125×2	200×1	32×1	65×1
300	234.0	3,660	3,660	2,700	740	1,820	3,870	1,600	3.7×2	150×2	200×1	32×1	65×1
350	273.0	3,860	4,060	2,700	830	2,100	4,720	1,800	3.7×2	100×4	150×2	32×1	65×2
400	312.0	3,860	4,460	2,700	830	2,280	5,090	1,800	5.5×2	125×4	150×2	32×2	65×2
450	351.0	4,060	4,860	2,700	850	2,600	5,680	2,000	5.5×2	125×4	200×2	32×2	65×2
500	390.0	4,060	5,660	2,700	850	2,770	6,260	2,000	5.5×2	125×4	200×2	32×2	65×2
600	468.0	3,860	7,260	2,700	830	3,390	7,590	1,800	3.7×3	150×4	200×2	32×2	65×2
700	546.0	4,060	8,460	2,700	850	4,050	9,280	2,000	5.5×3	125×6	200×3	32×2	65×3
800	624.0	4,060	8,860	2,700	850	4,200	9,610	2,000	3.7×4	125×8	200×3	32×3	65×3
900	702.0	3,860	11,260	2,700	830	5,300	11,770	1,800	5.5×4	125×8	200×3	32×3	65×3
1000	780.0	4,060	11,260	2,700	850	5,270	11,900	2,000	5.5×4	125×8	200×3	32×3	65×3

標準形運転音<MS・Lc形>

単位：dB<A>

低騒音形運転音<ME・Lc形>

単位：dB<A>

機種	側板横<m>			ルーバ横<m>×高さ1.5m				ファン斜45°
	2	5	10	2	5	10	20	
MS・Lc	2	5	10	2	5	10	20	D
100	61	58	55	65	60	56	51	75
125	61	58	55	65	60	56	51	74
150	64	60	58	68	63	59	54	77
175	65	62	59	69	64	60	55	77
200	65	62	59	69	65	60	56	78
225	64	61	58	69	64	60	55	76
250	63	60	57	67	63	59	54	74
300	66	62	60	73	68	64	59	81
350	65	62	59	72	68	63	59	80
400	66	62	60	73	68	64	59	80
450	64	61	59	71	67	63	58	78
500	65	63	60	72	68	64	59	79
600	65	62	59	73	69	65	61	81
700	65	62	60	74	70	66	61	80
800	66	62	60	75	71	67	62	81
900	67	64	61	76	72	68	64	82
1000	65	63	60	75	71	67	62	80

機種	側板横<m>			ルーバ横<m>×高さ1.5m				ファン斜45°
	2	5	10	2	5	10	20	
ME・Lc	2	5	10	2	5	10	20	D
100	56	53	50	59	55	50	46	66
125	57	54	51	61	57	53	48	67
150	59	56	53	64	59	55	50	70
175	60	57	54	64	60	55	51	69
200	61	58	56	66	61	57	52	71
225	61	59	56	66	61	57	52	71
250	60	57	55	65	60	56	51	71
300	60	57	54	67	63	58	54	73
350	61	58	55	68	64	60	55	74
400	63	60	57	70	66	62	57	75
450	63	60	57	70	66	61	57	74
500	63	60	57	70	66	62	57	74
600	61	58	56	70	66	62	57	74
700	61	58	55	69	65	61	57	74
800	62	59	56	71	67	63	59	75
900	61	59	56	70	67	63	58	75
1000	63	60	57	72	68	64	60	75

(c)超低騒音Ⅰ形<MQ・Lc形>

機種	水量 <m ³ /h>	外形寸法				重量		送風機		配管サイズ<A>			
		L <mm>	W <mm>	H <mm>	h <mm>	製品 <kg>	運転 <kg>	径 <D>	定格出力 <kW>×台	入口	出口	自動 手動	オーバ 排水
100	78.0	3,460	1,860	2,700	710	1,040	2,200	1,400	2.2×1	80×2	125×1	25×1	65×1
125	97.5	3,660	2,060	2,700	740	1,120	2,400	1,600	2.2×1	100×2	125×1	25×1	65×1
150	117.0	3,860	2,060	2,700	830	1,150	2,450	1,800	2.2×1	100×2	150×1	25×1	65×1
175	136.5	4,060	2,260	2,700	850	1,210	2,640	2,000	3.7×1	100×2	150×1	25×1	65×1
200	156.0	4,060	2,460	2,700	850	1,370	2,910	2,000	3.7×1	125×2	150×1	32×1	65×1
225	175.5	4,060	2,860	2,700	850	1,480	3,220	2,000	5.5×1	125×2	200×1	32×1	65×1
250	195.0	4,060	3,660	2,700	850	1,760	3,910	2,000	5.5×1	125×2	200×1	32×1	65×1
300	234.0	3,660	4,060	2,700	740	2,080	4,640	1,600	3.7×2	100×4	150×2	32×1	65×2
350	273.0	3,860	4,460	2,700	830	2,250	5,060	1,800	3.7×2	100×4	150×2	32×1	65×2
400	312.0	4,060	4,860	2,700	850	2,560	5,640	2,000	3.7×2	125×4	150×2	32×2	65×2
450	351.0	4,060	5,660	2,700	850	2,800	6,290	2,000	5.5×2	125×4	200×2	32×2	65×2
500	390.0	3,860	6,460	2,700	830	3,230	7,040	1,800	3.7×3	125×4	200×2	32×2	65×2
600	468.0	3,860	7,260	2,700	830	3,420	7,630	1,800	3.7×3	150×4	200×2	32×2	65×2
700	546.0	3,860	8,860	2,700	830	4,290	9,570	1,800	3.7×4	100×8	200×3	32×2	65×3
800	624.0	4,060	9,660	2,700	850	4,910	10,720	2,000	3.7×4	125×8	200×3	32×3	65×3
900	702.0	4,060	11,260	2,700	850	5,330	11,960	2,000	5.5×4	125×8	200×3	32×3	65×3
1000	780.0	4,060	12,060	2,700	850	6,030	13,030	2,000	3.7×5	125×10	200×3	32×3	65×3

(d)超低騒音Ⅱ形<MQQ・Lc形>

機種	水量 <m ³ /h>	外形寸法				重量		送風機		配管サイズ<A>			
		L <mm>	W <mm>	H <mm>	h <mm>	製品 <kg>	運転 <kg>	径 <D>	定格出力 <kW>×台	入口	出口	自動 手動	オーバ 排水
100	78.0	3,660	2,060	2,700	740	1,120	2,400	1,600	2.2×1	80×2	125×1	25×1	65×1
125	97.5	3,860	2,260	2,700	830	1,200	2,610	1,800	2.2×1	100×2	125×1	25×1	65×1
150	117.0	3,860	2,460	2,700	830	1,340	2,850	1,800	2.2×1	100×2	150×1	25×1	65×1
175	136.5	4,060	2,860	2,700	850	1,740	3,880	2,000	2.2×1	100×2	150×1	25×1	65×1
200	156.0	3,460	3,660	2,700	710	1,800	3,800	1,400	2.2×2	125×2	150×1	32×1	65×1
225	175.5	3,660	3,660	2,700	740	1,830	3,880	1,600	2.2×2	125×2	200×1	32×1	65×1
250	195.0	3,860	4,060	2,700	830	2,110	4,720	1,800	2.2×2	100×4	125×2	32×1	65×2
300	234.0	4,060	4,460	2,700	850	2,230	5,110	2,000	2.2×2	100×4	150×2	32×1	65×2
350	273.0	4,060	5,660	2,700	850	2,730	6,220	2,000	2.2×2	100×4	150×2	32×1	65×2
400	312.0	3,660	6,460	2,700	740	3,100	6,810	1,600	2.2×3	125×4	150×2	32×2	65×2
450	351.0	3,860	7,260	2,700	830	3,420	7,620	1,800	2.2×3	125×4	200×2	32×2	65×2
500	390.0	4,060	7,260	2,700	850	3,460	7,760	2,000	2.2×3	125×4	200×2	32×2	65×2
600	468.0	4,060	8,860	2,700	850	4,210	9,610	2,000	2.2×4	100×8	150×3	32×2	65×3
700	546.0	4,060	11,260	2,700	850	5,240	11,010	2,000	2.2×4	100×8	200×3	32×2	65×3
800	624.0	3,860	12,060	2,700	830	5,940	12,770	1,800	2.2×5	100×10	200×3	32×3	65×3
900	702.0	4,060	14,060	2,700	850	6,460	14,480	2,000	2.2×5	100×10	200×3	32×3	65×3
1000	780.0	4,060	16,860	2,700	850	7,660	17,080	2,000	2.2×6	100×12	200×3	32×3	65×3

超低騒音Ⅰ形運転音<MQ・Lc形> 単位：dB<A>

機種	側板横<m>			ルーバ横<m><高さ1.5m>				ファン斜45° D
	2	5	10	2	5	10	20	
100	53	50	47	56	52	47	42	65
125	53	50	47	57	52	48	43	64
150	55	52	50	59	54	50	45	66
175	56	53	50	59	54	52	46	66
200	57	54	51	61	56	52	47	68
225	58	55	53	61	57	53	48	69
250	57	55	52	62	57	53	48	68
300	57	54	51	64	59	55	50	71
350	57	54	52	64	60	56	51	71
400	57	54	51	64	60	56	51	70
450	58	55	53	65	61	57	52	70
500	56	53	51	64	60	56	52	70
600	59	56	53	67	63	59	55	72
700	57	54	52	66	63	59	54	72
800	57	54	51	66	62	59	54	71
900	58	55	53	67	63	59	55	72
1000	57	54	51	67	63	59	55	72

超低騒音Ⅱ形運転音<MQQ・Lc形> 単位：dB<A>

機種	側板横<m>			ルーバ横<m><高さ1.5m>				ファン斜45° D
	2	5	10	2	5	10	20	
100	51	48	45	53	48	44	39	57
125	52	49	46	55	50	46	41	59
150	53	50	47	57	52	48	43	61
175	53	50	48	58	53	49	44	61
200	53	49	47	58	54	49	45	64
225	52	49	47	58	54	49	45	63
250	52	49	46	58	54	49	45	61
300	53	50	48	60	56	52	47	63
350	53	50	48	60	56	52	47	63
400	53	50	48	61	57	53	48	65
450	53	50	47	61	57	53	48	64
500	53	50	48	62	57	53	49	64
600	53	50	48	62	58	54	50	65
700	53	50	48	62	58	54	50	64
800	54	51	48	63	60	56	51	66
900	53	51	48	63	59	56	51	65
1000	52	49	46	61	58	54	50	62

(3) 丸形構造図

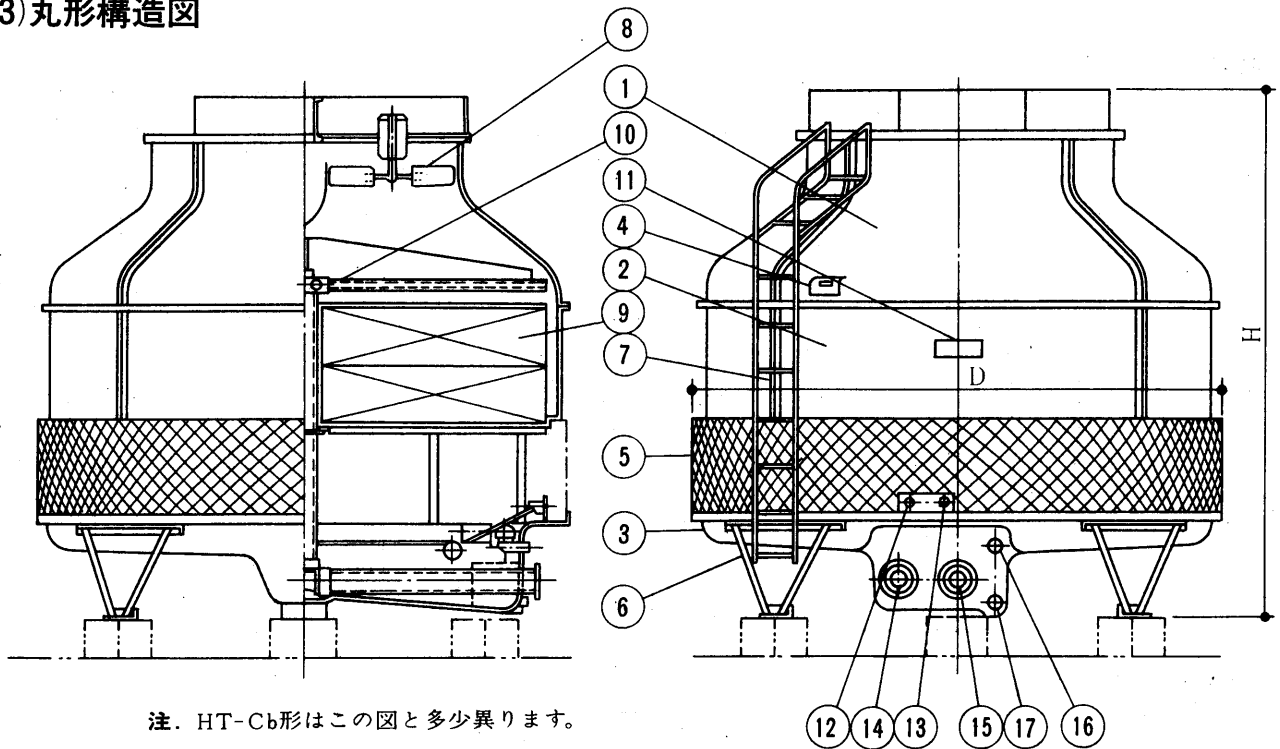

注. HT-Cb形はこの図と多少異なります。

- | | | |
|------------|---------------|---------------|
| 上部塔体.....① | トラップ.....⑦ | 自動給水口.....⑬ |
| 中部塔体.....② | ファン・モータ.....⑧ | 循環水出口.....⑭ |
| 下部塔体.....③ | 充填物.....⑨ | 循環水入口.....⑮ |
| 点検口.....④ | 散水装置.....⑩ | オーバーフロー.....⑯ |
| ルーバ.....⑤ | 銘板.....⑪ | 排水口.....⑰ |
| 脚.....⑥ | 手動給水口.....⑫ | |

(4) 角形構造図

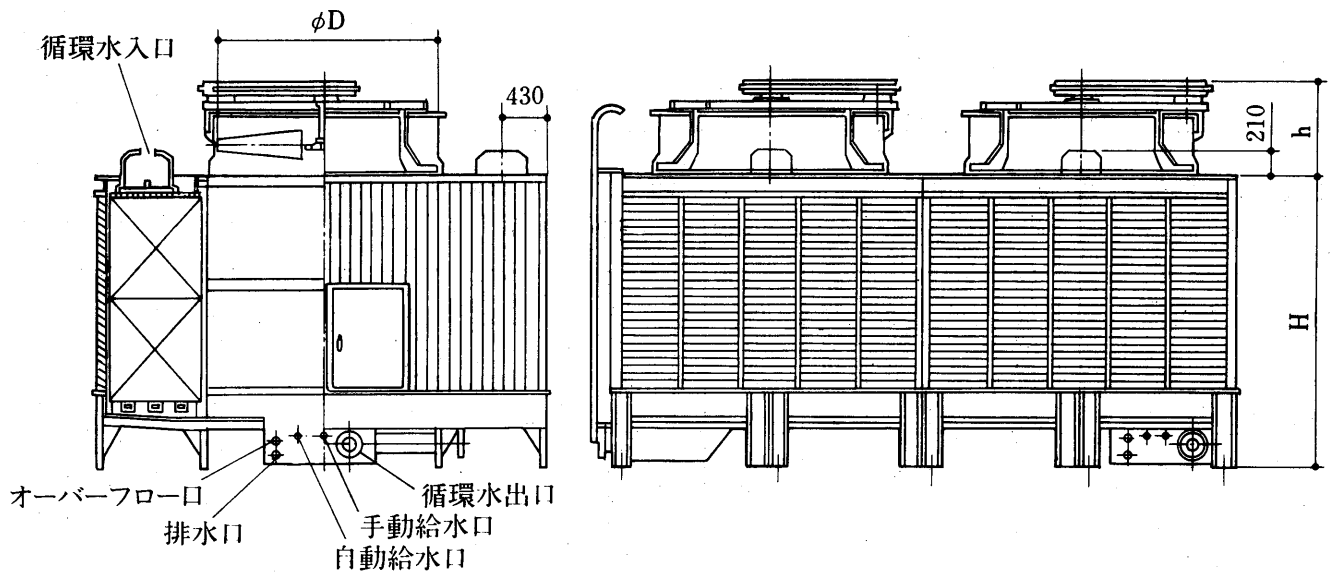

(5) 密閉式タワー

(a) 標準形〈PS形〉

機種	水量 m ³ /h	外形寸法			重量		送風機		配管サイズ〈A〉			散水ポンプ kW×台	管内損失水頭 〈mAq〉
		L	W	H	乾	湿	呼 称 または径	定格出力 kW×台	入口 出口	自動 手動	オーバ 排 水		
PS		mm	mm	mm	kg	kg							
30	23.4	2,215	1,980	2,450	1,000	1,900	OH-80JT	1.1×2	50×1	25×1	40×1	0.75×1	1.8
40	31.2	4,040	1,580	2,700	1,600	3,000	KG-80JT	1.1×2	80×2	25×1	80×1	2.2×1	0.8
50	39.0	3,840	1,980	2,700	1,800	3,300	KG-70JT	1.1×3	80×2	25×1	80×1	2.2×1	1.2
60	46.8	3,840	1,980	2,700	1,900	3,400	1,400	3.7×1	80×2	25×1	80×1	2.2×1	1.8
80	62.4	4,040	2,380	2,700	2,300	4,000	1,600	5.5×1	80×2	25×1	80×1	2.2×1	3.0
100	78.0	4,440	2,380	2,700	2,600	4,500	2,000	5.5×1	80×2	25×1	80×1	2.2×1	7.0
125	97.5	4,440	3,080	2,700	3,600	6,600	2,000	5.5×1	80×4	25×1	80×2	2.2×2	2.4
150	117.0	3,840	3,880	2,700	3,800	6,700	1,400	5.5×2	80×4	25×1	80×2	2.2×2	2.8
175	136.5	4,040	4,680	2,700	4,400	7,900	1,600	5.5×2	80×4	25×1	80×2	2.2×2	3.5
200	156.0	4,440	4,680	2,700	5,000	8,800	2,000	5.5×2	80×4	25×1	80×2	2.2×2	7.0
225	175.5	3,840	5,780	2,700	5,600	10,000	1,400	5.5×3	80×6	25×1	80×3	2.2×3	2.8
250	195.0	4,040	6,980	2,700	6,900	12,100	1,600	5.5×3	80×6	32×1	80×3	2.2×3	3.2
300	234.0	4,440	6,980	2,700	7,500	13,100	2,000	5.5×3	80×6	32×1	80×3	2.2×3	7.0
350	273.0	4,040	9,280	2,700	9,000	15,900	1,600	5.5×4	80×8	32×1	80×4	2.2×4	3.5
400	312.0	4,440	9,280	2,700	9,900	17,400	2,000	5.5×4	80×8	32×1	80×4	2.2×4	7.0
450	351.0	4,240	11,580	2,700	12,000	20,800	1,800	5.5×5	80×10	32×1	80×5	2.2×5	3.7
500	390.0	4,440	11,580	2,700	12,400	21,700	2,000	5.5×5	80×10	32×2	80×5	2.2×5	7.0

(b) 低騒音形〈PE形〉

機種	水量 m ³ /h	外形寸法			重量		送風機		配管サイズ〈A〉			散水ポンプ kW×台	管内損失水頭 〈mAq〉
		L	W	H	乾	湿	呼 称 または径	定格出力 kW×台	入口 出口	自動 手動	オーバ 排 水		
PE		mm	mm	mm	kg	kg							
30	23.4	2,215	2,380	2,450	1,200	2,100	OH-80JT	1.1×2	50×1	25×1	40×1	0.75×1	1.8
40	31.2	4,040	1,980	2,700	1,800	3,300	OH-80JT	1.1×2	80×2	25×1	80×1	2.2×1	0.8
50	39.0	4,040	2,380	2,700	2,200	3,900	OH-80JT	1.1×3	80×2	25×1	80×1	2.2×1	1.3
60	46.8	3,840	1,980	2,700	1,900	3,400	1,400	3.7×1	80×2	25×1	80×1	2.2×1	1.8
80	62.4	4,040	2,380	2,700	2,300	4,100	1,600	5.5×1	80×2	25×1	80×1	2.2×1	3.0
100	78.0	4,440	2,780	2,700	2,900	5,000	2,000	5.5×1	80×2	25×1	80×1	2.2×1	6.7
125	97.5	4,240	3,880	2,700	3,600	6,600	1,800	5.5×1	80×4	25×1	80×2	2.2×2	1.9
150	117.0	3,840	4,680	2,700	4,300	7,700	1,400	3.7×2	80×4	25×1	80×2	2.2×2	2.7
175	136.5	4,240	4,680	2,700	4,600	8,100	1,800	5.5×2	80×4	25×1	80×2	2.2×2	3.5
200	156.0	4,440	5,480	2,700	5,700	9,700	2,000	5.5×2	80×4	25×1	80×2	2.2×2	6.7
225	175.5	4,040	5,780	2,700	5,700	10,100	1,600	5.5×3	80×6	25×1	80×3	2.2×3	2.8
250	195.0	4,040	6,980	2,700	6,600	11,800	1,600	5.5×3	80×6	32×1	80×3	2.2×3	3.2
300	234.0	4,440	8,180	2,700	8,400	14,500	2,000	5.5×3	80×6	32×1	80×3	2.2×3	6.7
350	273.0	4,240	9,280	2,700	9,000	16,000	1,800	5.5×4	80×8	32×1	80×4	2.2×4	3.5
400	312.0	4,440	10,880	2,700	11,100	19,200	2,000	5.5×4	80×8	32×1	80×4	2.2×4	6.7
450	351.0	4,240	13,580	2,700	13,500	23,500	1,800	5.5×5	80×10	32×1	80×5	2.2×5	5.5
500	390.0	4,440	13,580	2,700	13,900	24,000	2,000	5.5×5	80×10	32×2	80×5	2.2×5	6.7

注. 超低騒音形〈PQ形〉も製作していますのでご相談ください。

(c) 構造と各部の名称

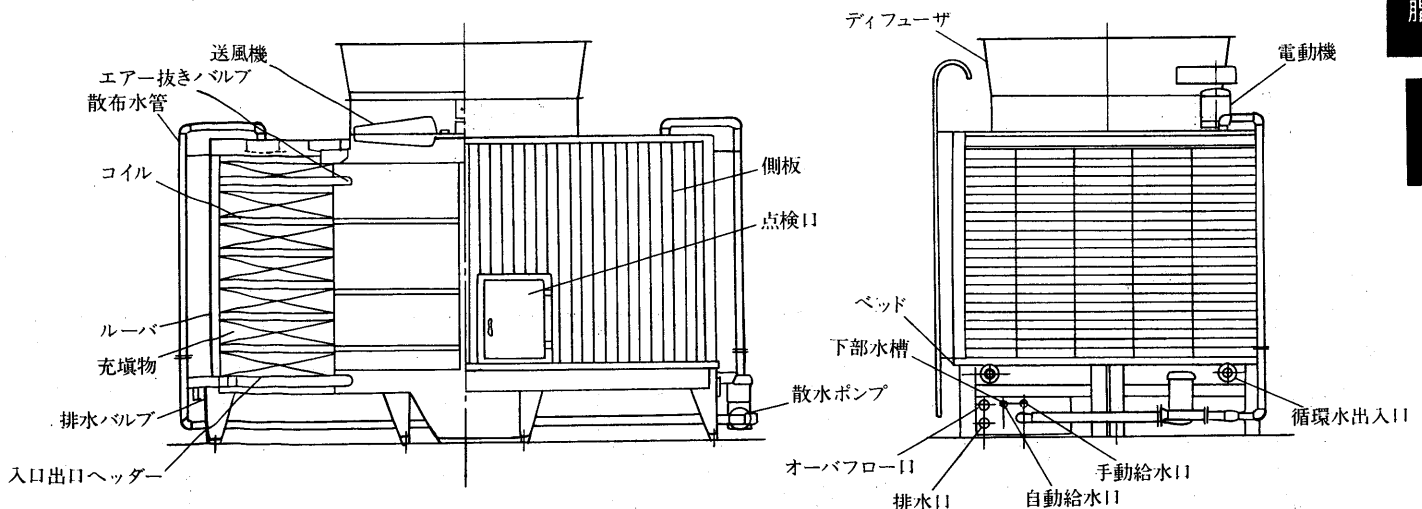

三菱樹脂

仕様

7.2 空研工業株式会社

〒810 福岡市中央区大濠公園2番39号
TEL 092<741>5031

耐震仕様

- (1)低騒音形<SKB-PoR>.....1200
- (2)低騒音形<SKB-PoGR>.....1201
- (3)超低騒音形<SKB-PoRS>...1202
- (4)超低騒音形<SKB-PoGRS>.....1203
- (5)密閉式低騒音形<KCMB-R>.....1204
- (6)密閉式超低騒音形<KCMB-RS>.....1205

(1)低騒音形<SKB-PoR>

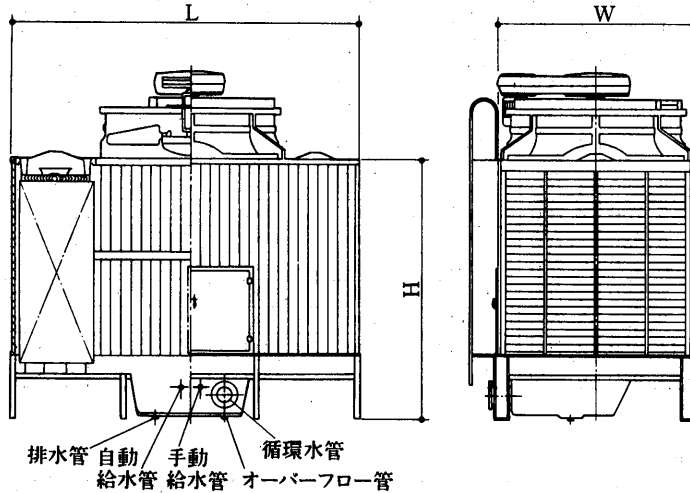

SKB-PoR仕様表

設計条件：水量13ℓ/min・RT 温度37°C→32°C<WB=27°C> 1RT=3,900kcal/h

形式 SKB-PoR	循環量 <ℓ/min>	外形寸法<mm>			空研軸流送風機		重量<kg>		接続管径<mm>				冷却容量 <RT>
		L	W	H	直径 <mm>	電動機 <kW>	乾	湿	循環水管	自・手動給水管	オーバーフロー管	排水管	
80	1,040	3,130	1,465	2,400	1,200	2.2	660	1,960	100	20	50	50	80
100	1,300	3,330	1,665	2,500	1,400	2.2	760	2,230	125				100
125	1,625	3,330	1,665	2,600	1,400	3.7	790	2,260	150				125
150	1,950	3,630	1,965	2,600	1,700	3.7	930	2,680	150	25	50	50	150
175	2,275	3,630	2,165	2,600	1,700	5.5	990	2,870					200
200	2,600	3,830	2,470	2,600	1,900	5.5	1,110	3,270	200	32	50	50	200
225	2,925	3,930	2,770	2,700	2,000	5.5	1,240	3,650					250
250	3,250	3,330	3,270	2,600	1,400×2	3.7×2	1,520	3,960	150×2	50	50×2	50×2	250
300	3,900	3,630	3,870	2,600	1,700×2	3.7×2	1,800	4,800					300
350	4,550	3,630	4,270	2,600	1,700×2	5.5×2	1,920	5,680	200×2	50	50×2	50×2	350
400	5,200	3,830	4,880	2,600	1,900×2	5.5×2	2,160	6,480					400
450	5,850	3,930	5,480	2,700	2,000×2	5.5×2	2,410	7,230	200×2	50	50×2	50×2	450
500	6,500	3,630	6,375	2,500	1,700×3	5.5×3	2,810	7,950					500
600	7,800	3,830	7,290	2,600	1,900×3	5.5×3	3,210	9,190	200×3	50×2	50×3	50×3	600
700	9,100	3,630	8,480	2,600	1,700×4	5.5×4	3,780	10,800					700
800	10,400	3,830	9,700	2,600	1,900×4	5.5×4	4,260	12,400	200×3	50×2	50×3	50×3	800
900	11,700	3,930	10,900	2,700	2,000×4	5.5×4	4,750	13,890					900
1,000	13,000	3,830	12,110	2,600	1,900×5	5.5×5	5,310	15,110					1,000

ルーバー面測定点 <D:送風機口径 最低1.5m>

側板面測定点

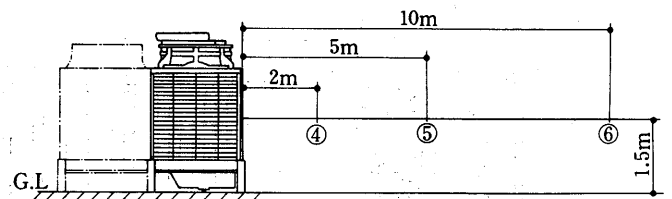
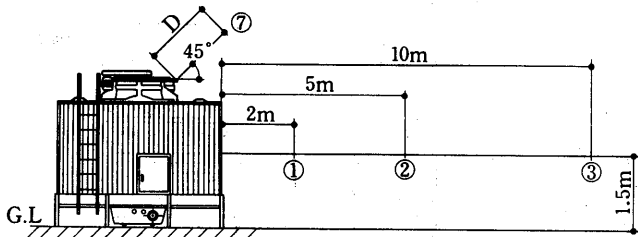

SKB-PoR音響値

単位：dB<A>

RT	測定点	①	②	③	④	⑤	⑥	⑦	RT	測定点	①	②	③	④	⑤	⑥	⑦
80		60	58	54	58	55	52	67	350		69	66	59	64	62	57	73
100		60.5	58	53	57	54	51	67	400		68	65	58	61	58	55	73
125		62.5	59	55	58	55	53	69	450		68	65	59	62	59	55	73
150		63	60	55	59	57	53	69	500		70	67	60	65	63	58	74
175		65	62	57	61	59	55	70	600		69	66	60	63	60	56	74
200		64	61.5	56	59	56	53	70	700		71	68	61	66	64	59	74
225		65	62.5	57	60	57	53	70	800		70	67	61	63	61	57	74
250		67	64	58	62	59	56	72	900		70	67	61	64	61	57	74
300		68	64	57	63	60	55	72	1,000		71	68	62	63	61	58	74

(2)低騒音形(SKB-PoGR)

SKB-PoGR仕様表

設計条件：水量0.995m³/h・RT 温度37.7℃→32℃(WB=27℃) 1RT=5,670kcal/h

形 式 SKB-PoGR	循環 水量 <m ³ /h>	外形寸法<mm>			空研軸流送風機		重量<kg>		接続管径<mm>				冷却 容量 <RT>
		L	W	H	直 径 <mm>	電動機 <kW>	乾	湿	循環 水管	自・手動 給水管	オ ー バ フ ロー 管	排水管	
71	70.8	3,130	1,465	2,500	1,200	3.7	680	1,980	125	20	50	50	71
75	75.0	3,130	1,465	2,700	1,200	3.7	710	2,010					75
78	77.4	3,130	1,565	2,700	1,200	3.7	730	2,090					78
85	84.6	3,330	1,665	2,600	1,400	3.7	790	2,260	25	20	50	50	85
90	89.4	3,330	1,665	2,700	1,400	3.7	800	2,270					90
95	94.8	3,430	1,765	2,600	1,500	3.7	830	2,390					95
100	99.5	3,430	1,865	2,700	1,500	3.7	870	2,490	150	25	50	50	100
105	104.4	3,530	1,865	2,700	1,600	3.7	890	2,540					105
125	124.8	3,530	2,165	2,700	1,600	5.5	970	2,810					125
135	134.4	3,630	2,165	2,800	1,700	5.5	1,040	2,920	200	32	50	50	135
140	139.2	3,730	2,370	2,700	1,800	5.5	1,080	3,130					140
145	144.6	3,730	2,470	2,700	1,800	5.5	1,100	3,210					145
155	154.2	3,830	2,670	2,700	1,900	5.5	1,180	3,470	150×2	50	50×2	50×2	155
160	159.6	3,930	2,770	2,700	2,000	5.5	1,240	3,650					160
170	169.2	3,930	2,770	2,700	2,000	7.5	1,250	3,660					170
180	179.4	3,330	3,270	2,700	1,400×2	3.7×2	1,540	3,980	200	32	50	50	180
185	184.4	3,330	3,470	2,700	1,400×2	3.7×2	1,580	4,140					185
195	194.4	3,430	3,670	2,600	1,500×2	3.7×2	1,640	4,380					195
205	204.0	3,530	3,670	2,600	1,600×2	3.7×2	1,680	4,480	200	32	50	50	205
215	214.2	3,530	3,870	2,700	1,600×2	3.7×2	1,760	4,680					215
225	224.4	3,630	4,070	2,700	1,700×2	3.7×2	1,880	5,000					225
240	238.8	3,530	4,070	2,600	1,600×2	5.5×2	1,800	4,860	150×2	50	50×2	50×2	240
250	249.0	3,530	4,270	2,700	1,600×2	5.5×2	1,880	5,060					250
255	253.8	3,630	4,270	2,600	1,700×2	5.5×2	1,920	5,180					255
270	268.8	3,630	4,270	2,800	1,700×2	5.5×2	2,010	5,770	200×2	50	50×2	50×2	270
280	279.0	3,730	4,680	2,700	1,800×2	5.5×2	2,100	6,200					280
290	288.5	3,730	4,880	2,700	1,800×2	5.5×2	2,140	6,360					290
305	303.6	3,730	5,080	2,800	1,800×2	5.5×2	2,250	6,610	200×2	50	50×2	50×2	305
320	318.6	3,530	5,775	2,700	1,600×3	3.7×3	2,610	7,240					320
335	333.6	3,530	6,075	2,800	1,600×3	3.7×3	2,740	7,580					335
350	348.6	3,430	6,075	2,600	1,500×3	5.5×3	2,610	7,330	200×2	50	50×2	50×2	350
365	363.6	3,430	6,375	2,700	1,500×3	5.5×3	2,730	7,630					365

注1.外形図・音響値測定点は前頁と同じ。

SKB-PoGR 音響値

単位：dB(A)

測定点 RT	①	②	③	④	⑤	⑥	⑦
71	68	64	59	63	59	56	72
75	68	64	59	63	59	56	72
78	68	64	59	63	59	56	72
85	67	63	57	61	58	55	71
90	67	63	57	61	58	55	71
95	66	61	55	60	58	54	69
100	66	61	55	60	58	54	69
105	67	63	57	62	58	54	70
125	70	66	60	65	61	58	73
135	67	64	57	62	60	55	71
140	67	64	57	61	59	55	71
145	67	64	57	61	59	55	71
155	66	63	56	59	56	53	71
160	66	63	57	60	57	53	71
170	68	65	58	62	59	57	72
180	69	65	59	63	60	57	73

測定点 RT	①	②	③	④	⑤	⑥	⑦
185	69	65	59	63	60	57	73
195	68	63	57	62	60	56	71
205	69	65	59	64	60	56	72
215	69	65	59	64	60	56	72
225	68	64	57	63	60	55	72
240	72	68	62	67	63	60	75
250	72	68	62	67	63	60	
255	69	66	59	64	62	57	73
270	69	66	59	64	62	57	73
280	69	66	59	63	61	57	73
290	69	66	59	63	61	57	73
305	69	66	59	63	61	57	73
320	70	66	60	65	61	57	73
335	70	66	60	65	61	57	73
350	72	67	60	66	63	59	75
365	72	67	60	66	63	59	75

(3)超低騒音形<SKB-PoRS>

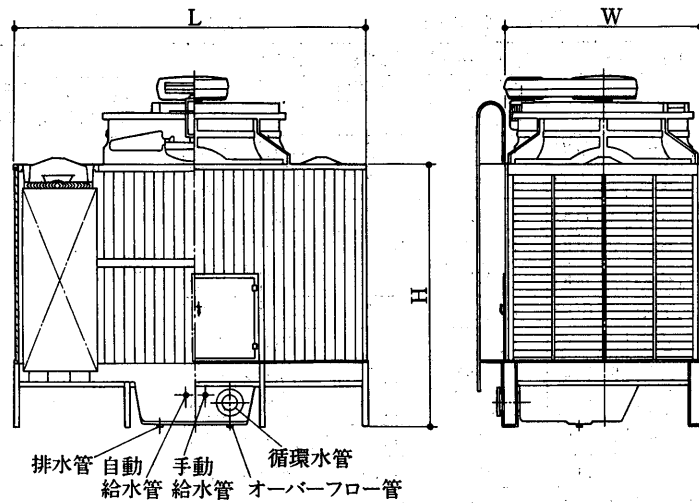

SKB-PoRS仕様表

設計条件：水量13ℓ/min・RT 温度37℃→32℃<WB=27℃> 1RT=3,900kcal/h

形式 SKB-PoRS	循環水量 <ℓ/min>	外形寸法<mm>			空研軸流送風機		重量<kg>		接続管径<mm>				冷却容量 <RT>			
		L	W	H	直径 <mm>	電動機 <kW>	乾	湿	循環水管	自・手動給水管	オーバーフロー管	排水管				
80	1,040	3,230	1,565	2,400	1,300	2.2	710	2,090	100	20	50	50	80			
100	1,300	3,430	1,765	2,400	1,500	2.2	800	2,360	125				100			
125	1,625	3,430	1,765	2,500	1,500	3.7	830	2,390	150	25			125			
150	1,950	3,630	2,165	2,700	1,700	3.7	1,010	2,890					150	150		
175	2,275	3,730	2,370	2,500	1,800	5.5	1,040	3,090	200	32			175			
200	2,600	3,930	2,470	2,700	2,000	5.5	1,180	3,380					200	200		
225	2,925	3,930	2,770	2,900	2,000	5.5	1,300	3,710	150×2	50	50×2	225				
250	3,250	3,430	3,470	2,500	1,500×2	3.7×2	1,610	4,230				250				
300	3,900	3,530	4,270	2,700	1,600×2	3.7×2	1,880	5,060	200×2			50	50×2	300		
350	4,550	3,730	4,680	2,500	1,800×2	5.5×2	2,030	6,130						350		
400	5,200	3,930	4,880	2,700	2,000×2	5.5×2	2,290	6,690	200×2					50	50×2	400
450	5,850	3,930	5,480	2,900	2,000×2	5.5×2	2,530	7,350								450
500	6,500	3,730	6,075	2,700	1,800×3	5.5×3	2,940	7,990	200×3	50×2	50×3					500
600	7,800	3,930	7,290	2,700	2,000×3	5.5×3	3,400	9,500								600
700	9,100	3,730	9,300	2,500	1,800×4	5.5×4	4,010	11,710	200×3			50×2	50×3			700
800	10,400	3,930	9,700	2,700	2,000×4	5.5×4	4,510	12,810								800
900	11,700	3,730	11,610	2,600	1,800×5	5.5×5	5,110	14,360	200×3					50×2	50×3	900
1,000	13,000	3,930	12,110	2,700	2,000×5	5.5×5	5,620	15,620								1,000

ルーバー面測定点<D:送風機口径,最低1.5m>

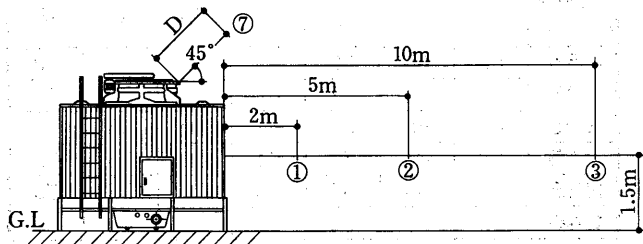

側板面測定点

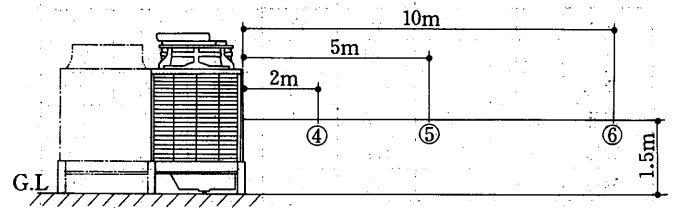

SKB-PoRS音響値

単位：dB<A>

RT	測定点							RT	測定点						
	①	②	③	④	⑤	⑥	⑦		①	②	③	④	⑤	⑥	⑦
80	55.5	53	50	54	51	50	65	350	65	60	55	60	57	54	70
100	56.5	54	50	55	52	49	65	400	65	60	55	59	56	53	70
125	57.5	55	51	55	53	50	66	450	65	60	55	59	56	53	70
150	59	56.5	51	56	53	51	67	500	66	61	56	61	58	54	71
175	60	56.5	52	57	54	51	67	600	66	62	56	60	57	54	70
200	61	57	53	57	54	51	68	700	67	62	57	61	58	54	72
225	62	58	53	57	54	51	68	800	67	63	57	61	58	55	71
250	63	59	54	59	57	53	70	900	67	63	57	61	58	55	71
300	64	60	54	60	57	53	70	1,000	67	64	58	61	59	56	71

(4)超低騒音形<SKB-PoGRS>

SKB-PoGRS仕様表

設計条件：水量0.995m³/h・RT 温度37.7℃→32℃<WB=27℃> 1RT=5,670kcal/h

形式 SKB-PoGRS	循環 水量 <m ³ /h>	外形寸法<mm>			空研軸流送風機		重量<kg>		接続管径<mm>				冷却 容量 <RT>
		L	W	H	直 径 <mm>	電動機 <kW>	乾	湿	循 環 水 管	自・手動 給水管	オーバ フロー管	排水管	
71	70.8	3,330	1,665	2,400	1,400	3.7	780	2,250	125	20	50	50	71
75	75.0	3,330	1,665	2,600	1,400	3.7	810	2,280					75
78	77.4	3,430	1,765	2,400	1,500	3.7	820	2,380					78
85	84.6	3,430	1,765	2,500	1,500	3.7	830	2,390					85
90	89.4	3,430	1,765	2,700	1,500	3.7	860	2,420					90
95	94.8	3,530	1,865	2,600	1,600	3.7	890	2,540		95			
100	99.5	3,530	1,865	2,700	1,600	3.7	910	2,560		100			
105	104.4	3,530	1,965	2,800	1,600	3.7	960	2,670		105			
125	124.8	3,730	2,065	2,700	1,800	5.5	1,020	2,870		125			
135	134.4	3,830	2,270	2,700	1,900	5.5	1,100	3,120		135			
140	139.2	3,830	2,470	2,700	1,900	5.5	1,140	3,300	140				
145	144.6	3,930	2,570	2,700	2,000	5.5	1,200	3,470	145				
155	154.2	3,930	2,770	2,800	2,000	5.5	1,280	3,690	155				
160	159.6	4,030	2,770	2,600	2,100	7.5	1,350	3,800	160				
170	169.2	4,030	2,770	2,700	2,100	7.5	1,390	3,840	170				
180	179.4	3,430	3,470	2,700	1,500×2	3.7×2	1,660	4,280	200	32	50	50	180
185	184.4	3,430	3,470	2,800	1,500×2	3.7×2	1,700	4,320					185
195	194.4	3,530	3,670	2,600	1,600×2	3.7×2	1,720	4,520					195
205	204.0	3,530	4,070	2,700	1,600×2	3.7×2	1,840	4,900					205
215	214.2	3,630	3,870	2,600	1,700×2	5.5×2	1,860	4,860					215
225	224.4	3,630	3,870	2,700	1,700×2	5.5×2	1,900	4,900		225			
240	238.8	3,730	4,270	2,600	1,800×2	5.5×2	2,000	5,320		240			
250	249.0	3,730	4,070	2,700	1,800×2	5.5×2	1,980	5,180		250			
255	253.8	3,730	4,270	2,700	1,800×2	5.5×2	2,020	5,340		255			
270	268.8	3,830	4,480	2,700	1,900×2	5.5×2	2,140	6,180		270			
280	279.0	3,830	4,880	2,700	1,900×2	5.5×2	2,220	6,540	280				
290	288.5	3,930	5,080	2,700	2,000×2	5.5×2	2,330	6,870	290				
305	303.6	3,930	5,280	2,800	2,000×2	5.5×2	2,430	7,110	200×2	50	50×2	50×2	305
320	318.6	3,530	6,075	2,800	1,600×3	3.7×3	2,800	7,640					320
335	333.6	3,630	5,775	2,600	1,700×3	5.5×3	2,760	7,510					335
350	348.6	3,630	6,075	2,700	1,700×3	5.5×3	2,880	7,810					350
365	363.6	3,630	6,375	2,800	1,700×3	5.5×3	3,010	8,150					365

注1.外形図・音響値測定点は前頁と同じ。

SKB-PoGRS音響値

単位：dB(A)

測定点 RT	①	②	③	④	⑤	⑥	⑦
71	61	57	52	57	54	51	68
75	61	57	52	57	54	51	68
78	62	58	52	58	55	51	68
85	62	58	52	58	55	51	68
90	62	58	52	58	55	51	68
95	62	58	52	58	55	51	68
100	62	58	52	58	55	51	68
105	62	58	52	58	55	51	68
125	63	58	53	58	55	52	68
135	63	58	53	57	54	51	68
140	63	58	53	57	54	51	68
145	63	59	53	57	54	51	68
155	63	59	53	57	54	51	68
160	64	60	55	58	55	51	69
170	64	60	55	58	55	51	69
180	64	60	54	60	57	53	70

測定点 RT	①	②	③	④	⑤	⑥	⑦
185	64	60	54	60	57	53	70
195	64	60	54	60	57	53	70
205	64	60	54	60	57	53	70
215	65	60	55	60	57	53	70
225	65	60	55	60	57	53	70
240	65	60	55	60	57	54	70
250	65	60	55	60	57	54	70
255	65	60	55	60	57	54	70
270	65	60	55	59	56	53	70
280	65	60	55	59	56	53	70
290	65	61	55	59	56	53	70
305	65	61	55	59	56	53	70
320	65	61	55	60	57	53	71
335	66	61	56	61	58	54	71
350	66	61	56	61	58	54	71
365	66	61	56	61	58	54	71

(5) 密閉式低騒音形 <KCMB-R>

<KCM-A> 5~15RT

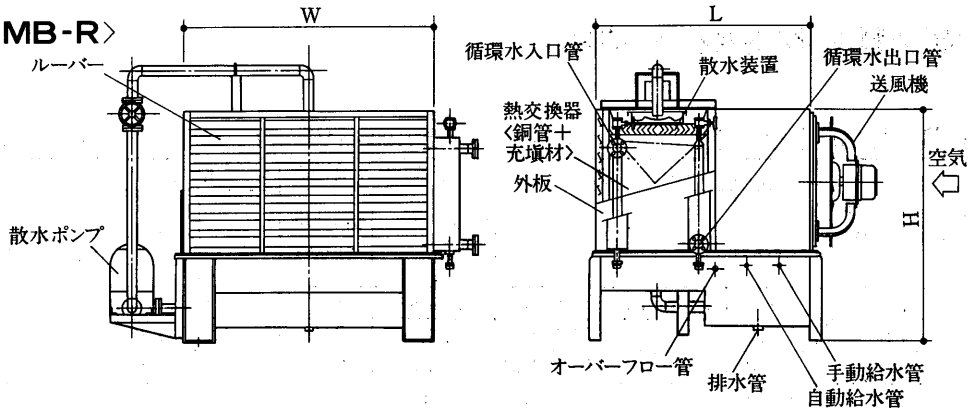

KCM-A仕様表

設計条件：水量13ℓ/min・RT 温度37℃→32℃ <W.B.27℃> 1RT=3,900kcal/h

形名 KCM-A	循環水量 <ℓ/min>	外形寸法<mm>			重量 湿 <kg>	送風機		散水ポンプ 電動機 <kW>	接続管径<mm>				
		L	W	H		直径 <mm>	電動機 <kW>		循環水 出入管	自動 給水管	手動 給水管	オーバ フロー管	排水 管
5	65	1,000	825	1,200	360	450	0.2	0.25	32	15	15	50	50
8	104	1,000	1,200	1,300	490	600	0.4		40				
10	130	1,100	1,200	1,300	510	600	0.75		50				
15	195	1,100	1,200	1,500	550	700	0.75		50				

密閉式<KCMC> 20~50RT

密閉式<KCMB> 60RT以上

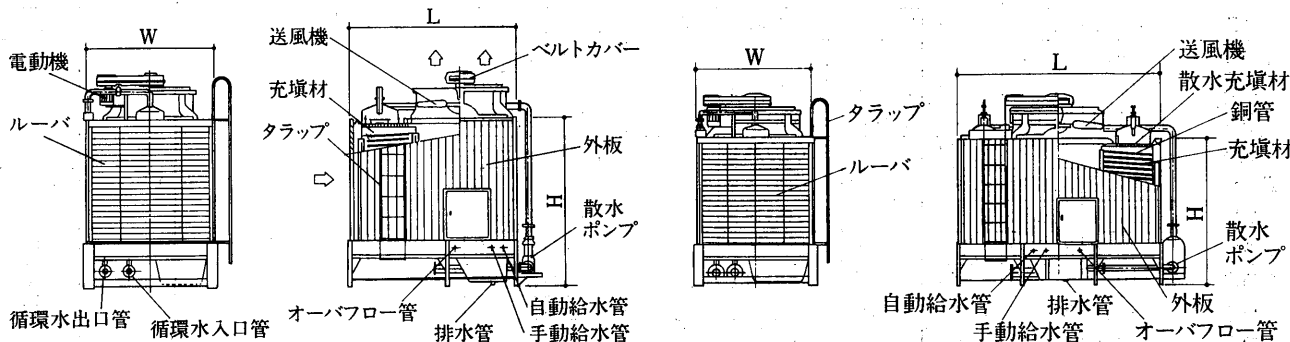

KCMC-R仕様表

設計条件：水量13ℓ/min・RT 温度37℃→32℃ <W.B.27℃> 1RT=3,900kcal/h

形名 KCMC-R	循環水量 <ℓ/min>	塔体寸法<mm>			空研軸流送風機		重量<kg>		管内 損失水頭 <mAq>	冷却 容量 <RT>	散水ポンプ<50/60Hz>		
		L	W	H	直径 <mm>	電動機 <kW>	乾	湿			散布水量 <ℓ/min>	電動機 <kW>	管径 <mm>
20	260	1,900	1,465	1,800	800	0.75	720	1,310	4.2	20	260	0.4	50
25	325	1,900	1,465	1,900	800	1.5	760	1,360	5.4	25			
30	390	2,100	1,665	2,000	950	1.5	840	1,570	5.8	30			
40	520	2,200	1,665	2,300	1,100	1.5	950	1,760	6.3	40			
50	650	2,300	1,865	2,800	1,200	2.2	1,160	2,290	7.4	50	330	0.75	

KCMB-R仕様表

設計条件：水量13ℓ/min・RT 温度37℃→32℃ <W.B.27℃> 1RT=3,900cal/h

形名 KCMB-R	循環水量 <ℓ/min>	塔体寸法<mm>			空研軸流送風機		重量<kg>		接続管径<mm>				管内 損失水頭 <mAq>	冷却 容量 <RT>	散水ポンプ<50/60Hz>		
		L	W	H	直径 <mm>	電動機 <kW>	乾	湿	循環水 出入口管	手動 給水管	オーバ フロー管	排水 管			散布水量 <ℓ/min>	電動機 <kW>	管径 <mm>
60	780	3,130	1,665	2,100	1,200	3.7	1,430	2,730	125	20	50	50	5.8	60	660	1.5/1.5	80
70	910	3,130	1,865	2,200	1,200	3.7	1,490	2,840	125	20	50	50	7.2	70			
80	1,040	3,430	1,865	2,400	1,500	3.7	1,710	3,290	125	20	50	50	7.6	80			
90	1,170	3,330	1,865	2,400	1,400	5.5	1,730	3,290	125	20	50	50	8.6	90			
100	1,300	3,430	1,865	2,800	1,500	5.5	1,930	3,600	125	20	50	50	7.4	100			
125	1,625	3,730	2,065	3,100	1,800	5.5	2,250	4,210	125	20	50	50	9.0	125	740	1.5/2.2	
150	1,950	3,330	3,670	2,300	1,400	3.7×2	3,250	6,320	125×2	25	50	50×2	7.4	150	1,320	1.5/1.5×2	
175	2,275	3,330	3,670	2,400	1,400	5.5×2	3,400	6,520	125×2	25	50	50×2	8.2	175			
200	2,600	3,430	3,670	2,800	1,500	5.5×2	3,790	7,110	125×2	25	50	50×2	7.4	200			
225	2,925	3,530	4,070	2,900	1,600	5.5×2	4,080	7,780	125×2	25	50	50×2	8.9	225			
250	3,250	3,730	4,070	3,100	1,800	5.5×2	4,390	8,310	125×2	25	50	50×2	9.0	250	1,980	1.5/1.5×3	
275	3,575	3,330	5,475	2,500	1,400	5.5×3	5,170	9,890	125×3	32	50	50×3	8.2	275			
300	3,900	3,430	5,475	2,800	1,500	5.5×3	5,640	10,630	125×3	32	50	50×3	7.4	300			
350	4,550	3,630	6,075	3,000	1,700	5.5×3	6,380	12,110	125×3	32	50	50×3	8.4	350			
400	5,200	3,430	7,280	2,800	1,500	5.5×4	7,490	14,140	125×4	25×2	50×2	50×4	7.4	400	2,960	1.5/2.2×4	
450	5,850	3,530	8,080	2,900	1,600	5.5×4	8,280	15,800	125×4	25×2	50×2	50×4	8.9	450			
500	6,500	3,730	8,080	3,100	1,800	5.5×4	8,710	16,540	125×4	25×2	50×2	50×4	9.0	500			
550	7,150	3,530	10,085	2,800	1,600	5.5×5	9,900	19,070	125×5	25×2	50×2	50×5	9.1	550			
600	7,800	3,730	10,085	3,000	1,800	5.5×5	10,670	20,380	125×5	25×2	50×2	50×5	8.8	600	3,700	1.5/2.2×5	

(6) 密閉式超低騒音形 <KCMB-RS>

KCMC-RS仕様表

設計条件：水量13ℓ/min・RT 温度37℃→32℃<W.B.27℃> IRT=3,900kcal/h

形名 KCMC-RS	循環水量 <ℓ/min>	塔体寸法<mm>			空研軸流送風機		重量<kg>		管内 損失水頭 <mAq>	冷却 容量 <RT>	散水ポンプ<50/60Hz>		
		L	W	H	直径 <mm>	電動機 <kW>	乾	湿			散布水量 <ℓ/min>	電動機 <kW>	管径 <mm>
20	260	1,900	1,465	1,900	800	0.75	750	1,340	3.8	20	260	0.4	50
25	325	2,300	1,665	2,000	1,200	1.5	910	1,680	4.2	25	300		
30	390	2,300	1,865	2,200	1,200	1.5	1,000	2,070	5.6	30	330		
40	520	2,300	1,865	2,400	1,200	2.2	1,090	2,180	7.1	40	0.75	50	
50	650	2,400	2,065	2,700	1,300	2.2	1,240	2,480	8.2	50			370

注. KCMA型は鋼板翼, KCMC・20RS型は耐食アルミ翼, その他の機種はFRP翼です。

KCMC-RS音響値 単位：dB<A>

測定点 RT	①	②	③	④	⑤	⑥	⑦
20	52	48	45	49	46	45	59
25	55	52	49	53	50	47	61
30	56	53	50	54	52	51	62
40	60	56	54	58	55	53	65

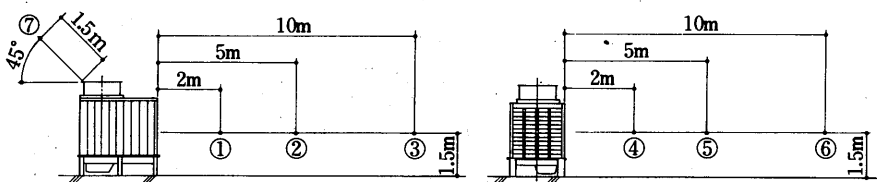

KCMB-RS仕様表

設計条件：水量13ℓ/min・RT 温度37℃→32℃<W.B.27℃> 1RT=3,900kcal/h

形名 KCMB-RS	循環水量 <ℓ/min>	塔体寸法<mm>			空研軸流送風機		重量<kg>		接続管径<mm>				管内 損失水頭 <mAq>	冷却 容量 <RT>	散水ポンプ<50/60Hz>		
		L	W	H	直径 <mm>	電動機 <kW>	乾	湿	循環水 出入口管	自・手動 給水管	オーバ フロー管	排水管			散布水量 <ℓ/min>	電動機 <kW>	管径 <mm>
60	780	3,330	2,065	2,200	1,400	2.2	1,630	3,250	125	20	50	50	6.9	60	740	1.5/2.2	80
70	910	3,330	2,065	2,200	1,400	3.7	1,640	3,260	125	20	50	50	8.9	70			
80	1,040	3,330	2,065	2,400	1,400	3.7	1,780	3,480	125	20	50	50	6.8	80			
90	1,170	3,430	2,065	2,700	1,500	3.7	1,940	3,710	125	20	50	50	7.4	90			
100	1,300	3,630	2,065	2,800	1,700	5.5	2,120	3,980	125	20	50	50	7.8	100			
125	1,625	3,730	2,065	3,200	1,800	5.5	2,330	4,310	125	20	50	50	8.1	125			
150	1,950	3,330	4,070	2,300	1,400	3.7×2	3,380	6,710	125×2	25	50	50×2	7.8	150			
175	2,275	3,430	4,070	2,600	1,500	3.7×2	3,700	7,210	125×2	25	50	50×2	7.5	175			
200	2,600	3,630	4,070	2,800	1,700	5.5×2	4,130	7,860	125×2	25	50	50×2	7.8	200			
225	2,925	3,730	4,070	2,900	1,800	5.5×2	4,300	8,150	125×2	25	50	50×2	8.4	225			
250	3,250	3,730	4,070	3,200	1,800	5.5×2	4,550	8,520	125×2	25	50	50×2	8.1	250			
275	3,575	3,530	6,075	2,700	1,600	3.7×3	5,720	11,130	125×3	32	50	50×3	7.6	275			
300	3,900	3,630	6,075	2,800	1,700	5.5×3	6,150	11,740	125×3	32	50	50×3	7.8	300			
350	4,550	3,730	6,075	3,000	1,800	5.5×3	6,470	12,300	125×3	32	50	50×3	8.4	350			
400	5,200	3,630	8,080	2,800	1,700	5.5×4	8,170	15,620	125×4	25×2	50×2	50×4	7.8	400			
450	5,850	3,730	8,080	2,900	1,800	5.5×4	8,520	16,220	125×4	25×2	50×2	50×4	8.4	450			
500	6,500	3,730	8,080	3,200	1,800	5.5×4	9,020	16,960	125×4	25×2	50×2	50×4	8.1	500			
550	7,150	3,730	10,085	2,900	1,800	5.5×5	10,490	20,040	125×5	25×2	50×2	50×5	8.6	550			
600	7,800	3,730	10,085	3,100	1,800	5.5×5	10,910	20,700	125×5	25×2	50×2	50×5	8.4	600			

ルーバ面測定点 <D：送風機口径, 最低1.5m>

側板面測定点

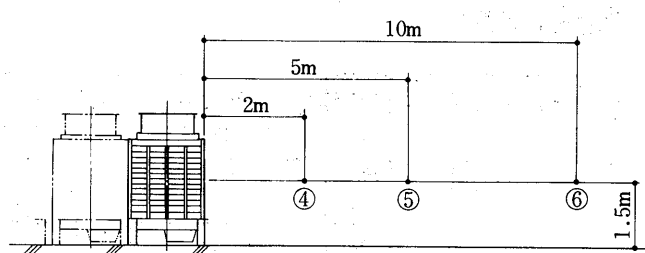
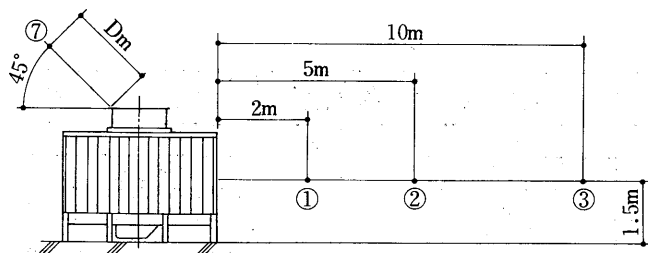

KCMB-RS音響値

単位：dB<A>

測定点 RT	①	②	③	④	⑤	⑥	⑦	測定点 RT	①	②	③	④	⑤	⑥	⑦
60	59	55	51	55	52	49	66	250	65	60	55	60	57	54	70
70	61	57	52	57	54	51	68	275	65	61	55	60	57	53	71
80	61	57	52	57	54	51	68	300	66	61	56	61	58	54	71
90	62	58	52	58	55	51	68	350	66	61	56	61	58	54	71
100	63	58	53	58	55	51	68	400	67	62	57	62	59	54	72
125	63	58	53	58	55	52	68	450	67	62	57	61	58	54	72
150	63	59	54	59	56	53	70	500	67	62	57	61	58	54	72
175	64	60	54	60	57	53	70	550	67	63	57	62	59	55	72
200	65	60	55	60	57	53	70	600	67	63	57	62	59	55	72
225	65	60	55	60	57	54	70								

資料1 三菱漏電遮断器仕様一覧表<標準シリーズ>

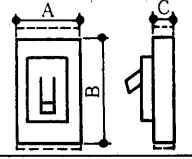
項目	形名	地絡保護専用品			過負荷・短絡・地絡保護兼用品							
		NV-G2N	NV-G3NA	NV-2F	NV30-CA	NV30-SA	NV50-CA	NV50-SA	NV100-CA	NV225-CA		
フレームの大きさ	A	30			50				100	225		
相線式		単相2W	三相3W 単相3W 単相2W	単相2W	三相3W 単相3W 単相2W	単相2W	三相3W 単相3W 単相2W	単相2W	三相3W 単相3W	三相3W 単相3W 単相2W		
定格電圧 <AC>	V	100-200			100・200 200-415	100-200		200-415		100-200 415		
定格電流	A	30 ※1		15, 20, 30		15, 20, 30, 40, 50			60, 75 100	125, 150 175, 200 225		
定格感度電流	mA	15, 30			<15> 30	30	15, 30 100	<15> 30	<15> 30 100 200	30, 100 200, <500>		
動作時間	ms以内	100										
漏電引きはずし方式		電子式電流動作形										
過電流引きはずし方式		無		熱動	完全電磁					熱動-電磁		
定格遮断電流 <sym>	AC100V	kA	1.5 ※2	1.5 ※2	1.5	2.5	5	2.5	5	—	10	22
	AC200V		1.5 ※2	1.5 ※2	1 ※3	2.5	5	2.5	5	5	7.5	15
	AC415V		—		—	—	5	—	—	5	5	7.5
外形寸法 	A	mm	68	90	68	70	90	70	90		105	
	B	mm	70	80	70	140	200	140	200		240	
	C	mm	40			52	68	52	68		86	
製品重量	kg	0.2	0.25	0.2	0.6	1.3	0.6	1.3	1.5	3.2		
電気用品型式認可	▽-41	取得済み										

- 注 1. 定格電圧100V-200V, 200V-415Vは両用を示します。
 2. ※1は最大通電電流を示します。
 3. < >は標準品を示します。
 4. ※2は定格短時間電流を示します。
 5. ※3は単相3W 200Vのときは1.5kAです。
 6. 遮断電流はsym<対称値>表示としています。
 7. 別に電設工事用としてGシリーズもあります。

ご発注の方法

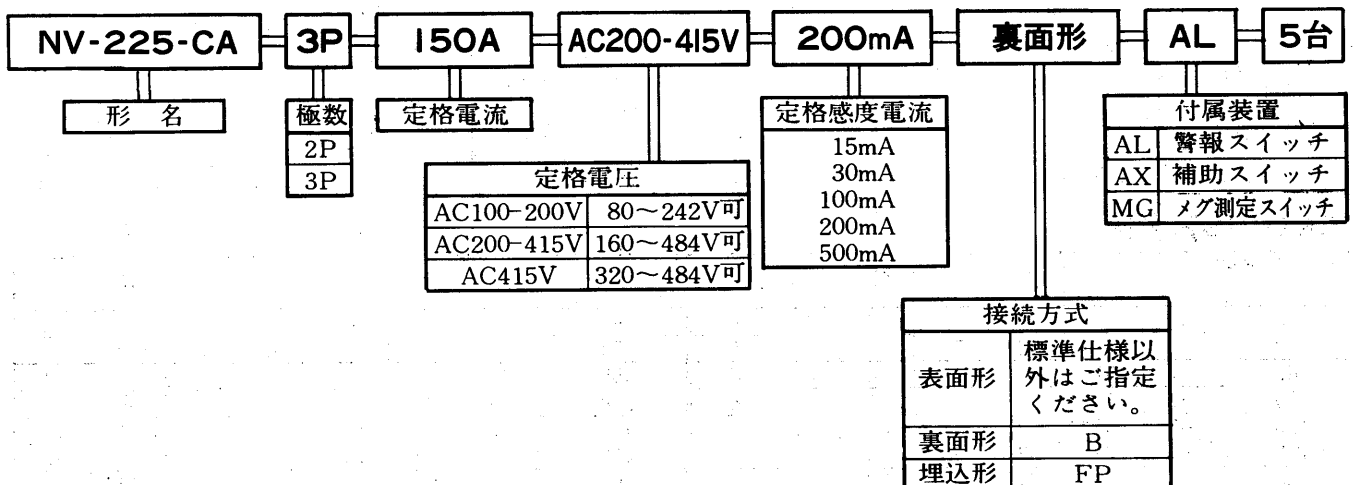

三菱電機株式会社

本社冷熱住設営業部	〒100 東京都千代田区丸の内2-2-3(三菱電機ビル)	(03)218-2979
北海道支社	〒060-91 札幌市中央区北2条西4丁目(北海道ビル)	(011)212-3731
東北支社	〒980 仙台市大町1-1-30(新仙台ビル)	(022)264-5645
新潟支社	〒950 新潟市東大通2-4-10(日本生命ビル)	(025)241-7224
北関東支社	〒331 大宮市大成町4-298	(0486)53-0251
北陸支社	〒920 金沢市小坂町西97	(0762)52-5801
中部支社	〒450 名古屋市中村区名駅3-28-12(大名古屋ビル)	(052)565-3220
関西支社	〒530 大阪市北区堂島2-2-2(近鉄堂島ビル)	(06)347-2371
中国支社	〒730 広島市中区中町7-32(日本生命ビル)	(082)248-5402
四国支社	〒760 高松市丸の内2-5(ヨンデンビル別館)	(0878)51-0005
九州支社	〒810 福岡市中央区天神2-12-1(天神ビル)	(092)721-2180
北海道三菱電機商品販売(株)	〒004 札幌市白石区大谷池434-21	(011)893-1392
東北三菱電機商品販売(株)	〒983 仙台市日の出町2-2-33	(022)231-2646
関東三菱電機商品販売(株)	〒330 大宮市大成町4-298(三菱電機大宮ビル)	(0486)51-3214
東関東三菱電機商品販売(株)	〒277 柏市東上町8-25	(0471)67-7231
東京三菱電機商品販売(株)	〒107 東京都港区南青山1-1-1(新青山ビル東館)	(03)475-3087
東京中央三菱電機商品販売(株)神田営業所	〒110 東京都台東区上野3-2-5	(03)835-2251
神奈川三菱電機商品販売(株)	〒231 横浜市中区富士見町3-4	(045)251-5751
北陸三菱電機商品販売(株)	〒920 金沢市小坂町西97	(0762)52-1156
中部三菱電機商品販売(株)	〒450 名古屋市中村区名駅3-28-12(大名古屋ビル)	(052)565-3380
近畿三菱電機商品販売(株)	〒612 京都市伏見区竹田小屋ノ内町11	(075)602-8401
関西三菱電機商品販売(株)	〒564 吹田市江坂町2-7-8	(06)338-8176
関西中央三菱電機商品販売(株)	〒556 大阪市浪速区日本橋3-10-6	(06)633-6010
関西特機営業所	〒530 大阪市北区堂島2-2-2(近鉄堂島ビル)	(06)347-2721
中国三菱電機商品販売(株)	〒733 広島市西区商工センター6-2-17	(082)273-1310
四国三菱電機商品販売(株)	〒760 高松市塩上町2-13-12	(0878)35-3911

昭和62年4月10日 印刷
昭和62年4月15日 発行

三菱電機冷熱ハンドブックⅠ 空調編

発行 三菱電機株式会社 東京都千代田区丸の内2-2-3

編集・(株)アド・メルコ
印刷・(株)博文堂